

Round wall vent with passive temperature sensing flow



## Product Description

The Ventient Round Wall Vent (RWV) is precision manufactured AES plastic vent for interior or exterior applications with passive temperature sensing flow control.

## Applications

Improvements in construction create buildings that are more airtight than previously, with the result that infiltration or leakiness is no longer providing a pathway for make-up air for exhaust systems.

Although many building are complying with building code requirements by having sufficient openable windows, changing lifestyle patterns, concerns about noise and security and generational differences mean that ventilation from open windows tends to be infrequent.

Unlike conventional systems such as operable windows or louvres, Proctor Ventient RWV can get on with the job of providing fresh air circulation regardless of occupancy.

As part of the total ventilation system Proctor Ventient can provide continuous ventilation to spaces even if they are unoccupied and is perfect for student accommodation, hotels, age care, healthcare and educational facilities.

Ventient is an ideal solution for residential buildings such as modern air tight homes and medium or high rise developments, as modern lifestyles mean that occupants are unable to manage purge ventilation and often return home to a stuffy environment.

## Installation

The Ventient Round Wall Vent is installed into a masonry or timber frame wall as shown on page 2

## Exhaust Make-up in Lieu of Supply

Where it is not possible to meet the code requirements for natural ventilation, or where the design preference is for a specific air change rate and 24 hour provision of fresh outside air without leaving windows open, Ventient, in conjunction with low energy, mechanical extract ventilation can provide or contribute to supply ventilation as required when calculated in accordance with AS1668.2.

## General Exhaust Make-Up Air

AS1668.2 draws to the attention of designers that increased air-tightness of modern buildings requires consideration of sources of make-up air. Make-up air drawn through gaps and service penetrations does not meet the requirements of Clause 2.3 within the standard and can lead to the loss of amenity in the enclosure. Ventient SFV could be an acceptable permanent natural ventilation opening as required in Clause 2.3.

## Sample Specification

Install Proctor Round Wall Vent (RWV) with shape memory

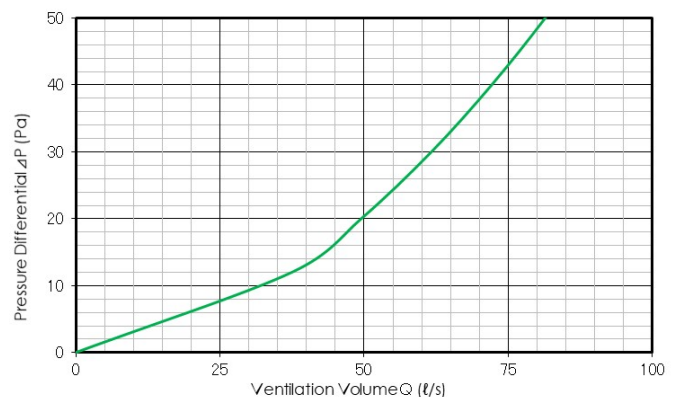

alloy thermal actuator in accordance with the user guide.

Optional features: (from table 2)

Product Code: VENTIENT RWV

SMA Temperature: A (3°C) / B (12°C)

Colour: Grey

# PROCTOR VENTIENT trickle ventilation system Round Wall Vent (RWV)

Round wall vent with passive temperature sensing flow control

Table 1 Performance	
Open area (A)	140cm <sup>2</sup>
Equivalent open area (aA)	84.5cm <sup>2</sup>
Ventilation Volume (Q) l/s	$Q = 33.5(\Delta P/9.8)^{0.54}$
Acoustic Ratings	The Ventient Sub Floor Vent is not an acoustic vent but can be used in conjunction with an acoustic duct.
Material	Highly UV resistant AES plastic
Ventilation volume (at $\Delta P$ )	12Pa: 37.4 L/s 30Pa: 61.6 L/s
Standard Sizes and colours	
Size (external facing)	External $\Phi$ 225mm Internal $\Phi$ 200mm Depth: 66mm
Colours	Masonry Grey 
Table 2 Features	
Shape Memory Alloy (SMA) Thermal actuator temperature set points*	Option:      A                      B Fully Open: > 18°C              > 12°C Closed: < 12°C                      < 5°C
Mesh to resist vermin, insects and embers	For bush fire compliance the vent can be supplied with a stainless steel mesh of maximum aperture of 2 mm.
Air filter	Not fitted as standard
Manual Operation	Open / Closed / Auto
Maintenance	Cover can be removed to clean the device.

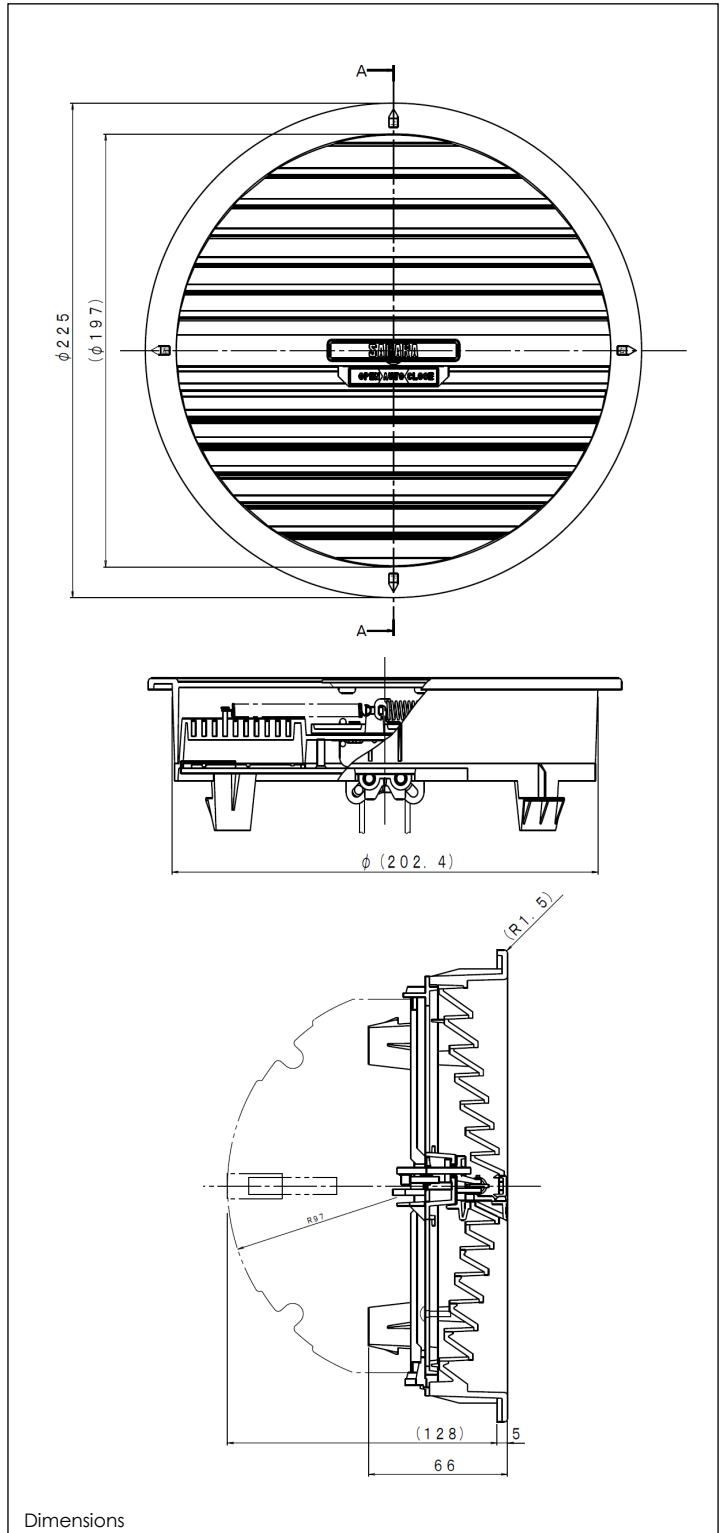
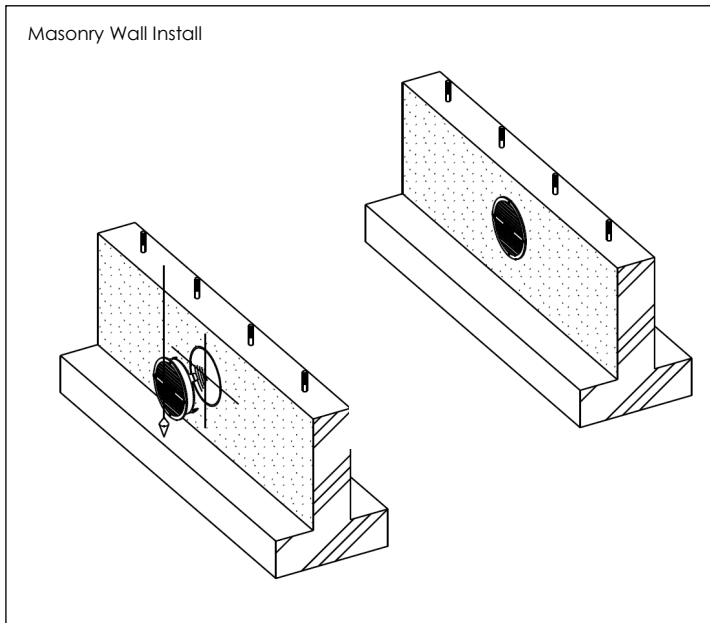

\*Note that the degree of opening may not always reflect the exterior temperature, as this will periodically differ from the ambient temperature where the SMA actuator is located closer to the interior. There is also a lag in adjustment to sharp changes in temperature.

The details supplied here are based upon good practice and currently available information. Advice regarding this product should be taken as a guide only. We reserve the right to change product specification without notice so please refer to our website for the latest version of this document. Please contact us to discuss your project and any technical enquires.